

SOLO RA1-35/50/60-9 R V.2

Power from

0.7 W

Air flow up to

60 m³/h

Sound pressure level from

16 dBA

The Solo ventilator is the most suitable solution for utility rooms, closets, and cloakrooms.

Low power consumption will save electricity by providing clean and fresh air to any room with area of up to 25 m².

The area is approximate and depends on the ventilation standards in your country and the model of the ventilator.



**ENERGY-SAVING
AND AFFORDABLE**

USER-FRIENDLY

Simple operation mechanism: speed switching using a pull cord switch.

CARING

Recovers heat energy and warms up supply air.
Helps control the air humidity level thanks to the built-in humidity sensor.

PRACTICAL

Prevents ingress of dust and foreign objects.



Easy to operate with the remote control.



Fresh and clean air where it is needed.



In cold weather it warms up fresh intake air to room temperature and exhausts stale air from the premise.



The humidity sensor and speed are controlled by the remote control.



Operation modes:

- Speed selection I II
- Humidity sensor ON ☰
- Night mode ☾

SIMPLICITY AND COMFORT

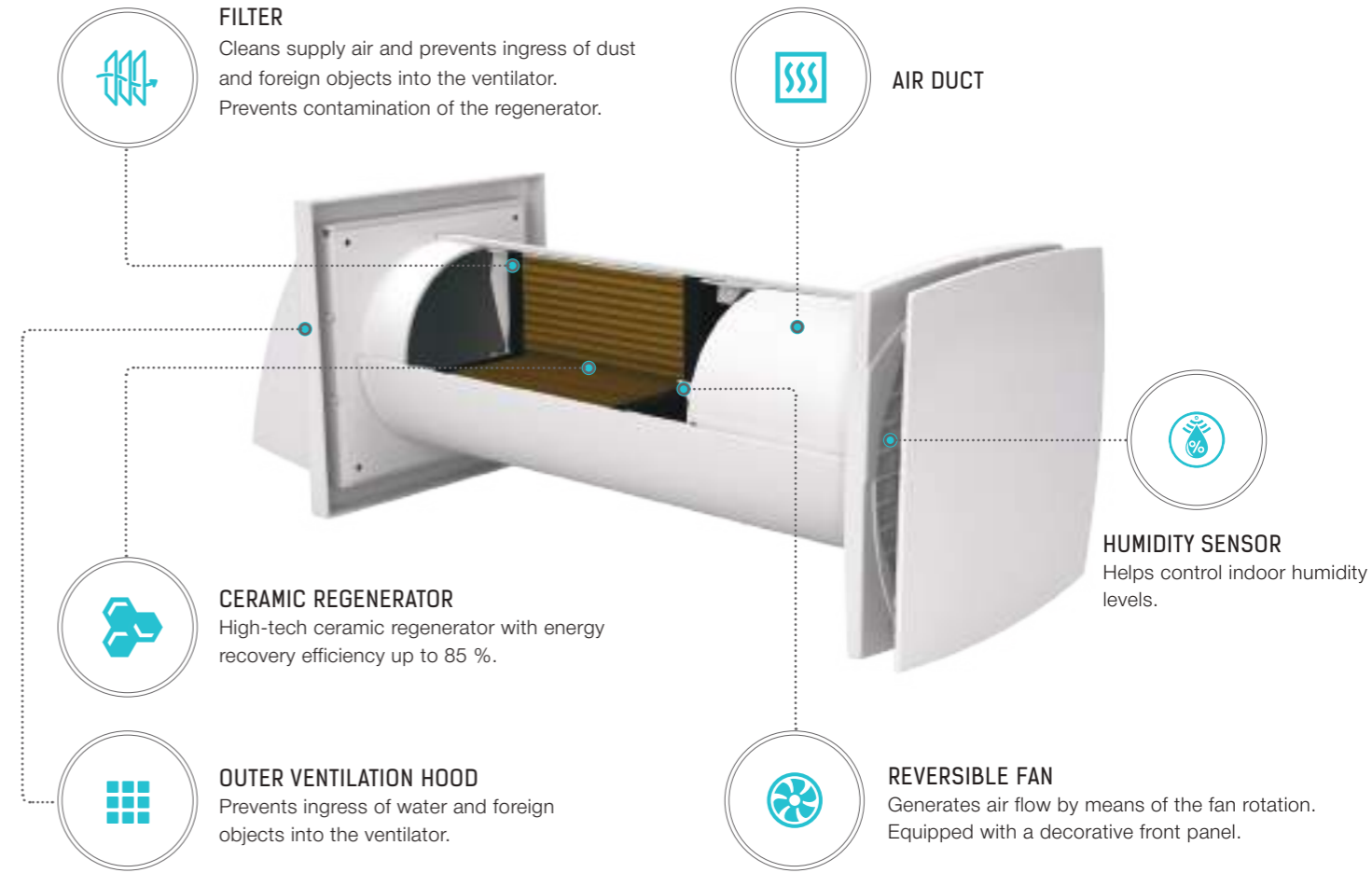

TECHNICAL DATA

Model	Solo RA1-35-9 R V.2		Solo RA1-50-9 R V.2		Solo RA1-60-9 R V.2	
	I	II	I	II	I	II
Speed						
Unit voltage [V/50 (60) Hz]	230					
Power [W]	1.50	2.30	0.70	2.30	1.10	3.20
Current [A]	0.046	0.047	0.020	0.034	0.021	0.042
Air flow in ventilation mode [m³/h (l/s)]	30(8)	46(13)	25(7)	50(14)	35(10)	60(17)
Sound pressure level at 3 m distance [dBA]	21	26	16	29	27	29
SFP [W/l/s]	0.36	0.36	0.20	0.33	0.23	0.38
Transported air temperature [°C]	-15...+40					
Regenerator type	Ceramic					
Energy recovery efficiency [%]	≤ 85					
SEC class	A					
Protection class	IP24					

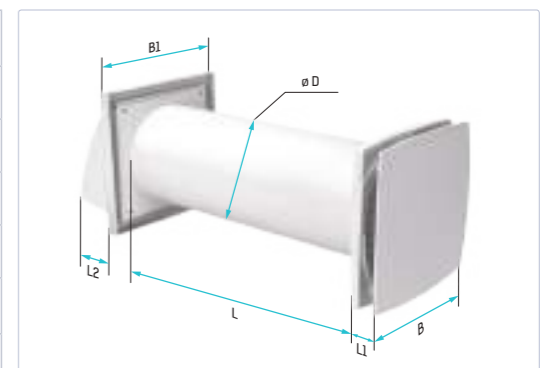

Модель	Dimensions [mm]					
	D	B	B1	L	L1	L2
Solo RA1-35-9 R V.2	107	150	153	305*~380	35	69
Solo RA1-50-9 R V.2	131	175	186	305~380	35	86
Solo RA1-60-9 R V.2	156	205	186	305~380	35	86

*Minimum wall thickness